

Autoclave Engineers

Valves, Fittings and Tubing

Condensed Catalog



**Autoclave
Engineers**



Fluid Components
Division of Snap-tite, Inc.



The world leader in high pressure valves, fittings and tubing

Since its inception in 1945, Autoclave Engineers has been dedicated to manufacturing high pressure valving systems which operate safely and reliably under extreme variations in temperature, pressure and environmental conditions. Today, Autoclave is a world leader in providing dependable high pressure valves, fittings and tubing, and serving applications in high pressure industries.

While Autoclave valves, fittings and tubing are known industry wide for their ability to operate at pressures in excess of 100,000 psi (6895 bar), a low pressure line for applications rated to 15,000 psi (1034 bar) is also available. Utilizing single ferrule compression sleeves which provide easy, leak free performance, the connection sizes come in 1/16 to 1/2 inches.

Low Pressure Valves, Fittings and Tubing

All Autoclave low pressure valves incorporate a rising stem/block design while the non-rotating feature of the stem prevents galling.

In addition, the valves are designed with metal to metal seating for bubble tight shut-off, long stem/seat life even in abrasive flow conditions and excellent overall corrosion resistance.

Three styles of low pressure valves are offered. The 10V, SW and MVE/MV series.

Pattern Options:

2-Way Straight

2-Way Angle

3-Way/2 on Pressure,

3-Way/1 on Pressure,

2-Way Angle with Replaceable Seat (not available in MVE/MV)

3-Way/2 Stem Manifold

Three different stem types are available. A vee stem is chosen when the application calls for direct on-off, metal to metal shut-off with fast opening capabilities. If an application calls for tighter flow control, AE offers a non-rotating regulating stem. For the most precise flow control, Autoclave recommends a micro metering stem design.

A complete line of tubing and fittings, as well as special items are available, providing all components required for our low pressure line. Autoclave components are offered in 316SS standard, but can be ordered in a variety of optional materials such as: Hastelloy B and C, Inconel, Monel, Nickel or Titanium.

For more information or to order a complete VFT Catalog, contact your Autoclave representative or the factory direct at 814-838-5700.

Manual Shut-off Valves



Autoclave valves are designed to operate safely and reliably at pressures to 150,000 psi (10342 bar). Several important features make this dependable service possible under widely varying conditions.

Non-rotating stem

Prevents stem/seat galling when valve is opened and closed.

Metal-to-Metal seating

Provides bubble-tight shut-off, longer stem/seat life in abrasive flow, greater durability for repeated on/off cycles and excellent corrosion resistance.

PTFE encapsulated packing

Ensures dependable stem and body sealing. The stem sleeve and packing gland materials extend thread life and reduce the handle torque required to operate the valve.

Manual valve options

Enables you to customize Autoclave valves to meet your specific application. Five different body patterns, a variety of materials and stem types, extreme temperature models, abrasive service options, panel mounting and several handle styles are among the available options.

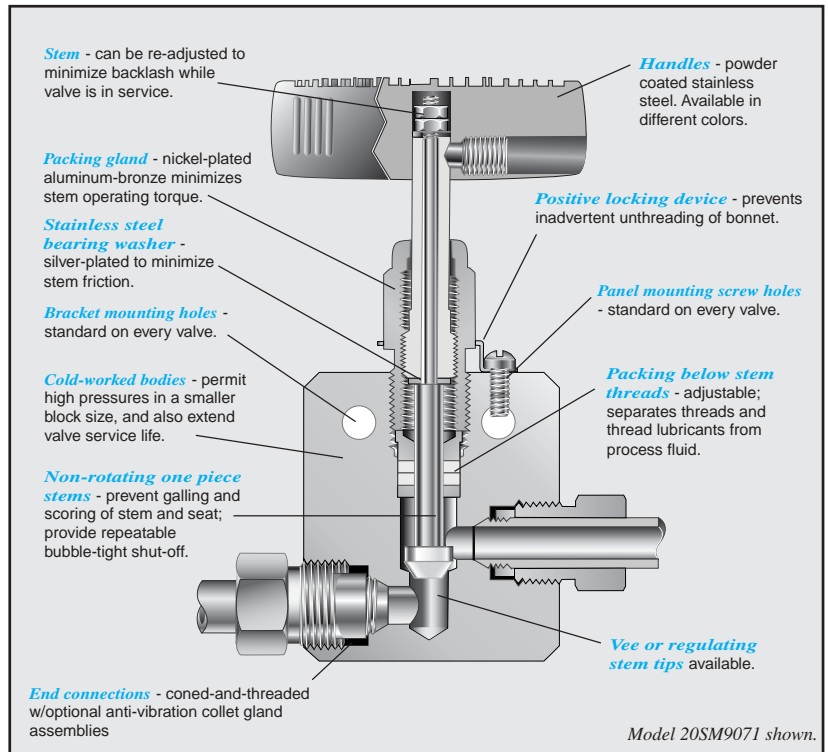

	O.D. Tube Size (In.)	Pressure Rating psi (bar)	*Rated Cv (full open)	Valve Stem Type							
					2-Way Straight	2-Way Angle	3-Way 2 On Pressure	3-Way 1 On Pressure	2-Way Angle Replaceable Seat	3-Way 2 Stem Manifold	
Medium Pressure	1/4 (6.35)	20,000 (1380)	.31	Vee Reg	20SM4071 20SM4081	20SM4072 20SM4082	20SM4073 20SM4083	20SM4074 20SM4084	20SM4872 20SM4882	20SM4075 20SM4085	
	3/8 (9.53)	20,000 (1380)	.75	Vee Reg	20SM6071 20SM6081	20SM6072 20SM6082	20SM6073 20SM6083	20SM6074 20SM6084	20SM6872 20SM6882	20SM6075 20SM6085	
	9/16 (14.3)	20,000 (1380)	1.30	Vee Reg	20SM9071 20SM9081	20SM9072 20SM9082	20SM9073 20SM9083	20SM9074 20SM9084	20SM9872 20SM9882	20SM9075 20SM9085	
	3/4 (19.1)	20,000 (1380)	2.50	Vee Reg	20SM12071 20SM12081	20SM12072 20SM12082	20SM12073 20SM12083	20SM12074 20SM12084	20SM12872 20SM12882	20SM12075 20SM12085	
	1 (25.4)	20,000 (1380)	4.40	Vee Reg	20SM16071 20SM16081	20SM16072 20SM16082	20SM16073 20SM16083	20SM16074 20SM16084	20SM16872 20SM16882	20SM16075 20SM16085	
	9/16 (14.30)	10,000 (690)	1.75	Vee Reg	10SM9071 10SM9081	10SM9072 10SM9082	10SM9073 10SM9083	10SM9074 10SM9084	10SM9872 10SM9882	10SM9075 10SM9085	
	3/4 (19.10)	10,000 (690)	2.80	Vee Reg	10SM12071 10SM12081	10SM12072 10SM12082	10SM12073 10SM12083	10SM12074 10SM12084	10SM12872 10SM12882	10SM12075 10SM12085	
	1 (25.40)	10,000 (690)	5.20	Vee Reg	10SM16071 10SM16081	10SM16072 10SM16082	10SM16073 10SM16083	10SM16074 10SM16084	10SM16872 10SM16882	10SM16075 10SM16085	
	High Pressure	1 (25.4)	30,000 (2070)	2.60	Vee Reg	30SC16071 30SC16081	30SC16072 30SC16082	30SC16073 30SC16083	30SC16074 30SC16084	30SC16872 30SC16882	30SC16075 30SC16085
		1/4 (6.35)	30,000 (2070)	.12	Vee Reg	30VM4071 30VM4081	30VM4072 30VM4082	30VM4073 30VM4083	30VM4074 30VM4084	30VM4872 30VM4882	30VM4075 30VM4085
3/8 (9.53)		30,000 (2070)	.23	Vee Reg	30VM6071 30VM6081	30VM6072 30VM6082	30VM6073 30VM6083	30VM6074 30VM6084	30VM6872 30VM6882	30VM6075 30VM6085	
9/16 (14.3)		30,000 (2070)	.33	Vee Reg	30VM9071 30VM9081	30VM9072 30VM9082	30VM9073 30VM9083	30VM9074 30VM9084	30VM9872 30VM9882	30VM9075 30VM9085	
9/16 (14.3)		40,000 (2760)	.28	Vee Reg	40VM9071 40VM9081	40VM9072 40VM9082	40VM9073 40VM9083	40VM9074 40VM9084	40VM9872 40VM9882	40VM9075 40VM9085	
1/4 (6.35)		60,000 (4140)	.08	Vee Reg	60VM4071 60VM4081	60VM4072 60VM4082	60VM4073 60VM4083	60VM4074 60VM4084	60VM4872 60VM4882	60VM4075 60VM4085	
3/8 (9.53)		60,000 (4140)	.09	Vee Reg	60VM6071 60VM6081	60VM6072 60VM6082	60VM6073 60VM6083	60VM6074 60VM6084	60VM6872 60VM6882	60VM6075 60VM6085	
9/16 (14.3)		60,000 (4140)	.14	Vee Reg	60VM9071 60VM9081	60VM9072 60VM9082	60VM9073 60VM9083	60VM9074 60VM9084	60VM9872 60VM9882	60VM9075 60VM9085	

*Cv Valves shown are for 2-way straight pattern. For 2-way angle, increase Cv Valve 50%. Note: SM Series replaces 20SC Series

Air Actuators (for AE Manual Valves)

Three sizes of air operators (medium, heavy duty or extra heavy) are offered for remote on-off operation or automatic operation of AE medium or high pressure valves. The actuators are available in air-to-open (normally closed) and air-to-close (normally open) designs.

Ordering Procedure (Consult factory to insure proper selection)

To order a valve with an air operator, select the duty rating and type of the air operator from the chart below. Add the air operator identifying suffix to the catalog number of the AE valve. To order a 2-way straight, 30VM vee stem, 9/16" (14.3 mm) valve with a medium duty air-to-close air operator, specify: ex: **30VM9071-C1S** for a yoke style piston air actuated valve or **30VM9071-CM** for an integral style diaphragm air operated valve.

Duty Rating	Operator	Type	Ordering Suffix
Medium	Diaphragm	Air-to-open	OM
		Air-to-close	CM
	Piston	Air-to-open	O1S
		Air-to-close	C1S
Heavy	Diaphragm	Air-to-open	OH
		Air-to-close	CH
	Piston	Air-to-open	O2S
		Air-to-close	C2S
Extra Heavy	Piston	Air-to-open	HO2S
		Air-to-close	HC2S





This table is designed to allow quick selection of an appropriate air actuator based on valve style and size, maximum system operating pressure and maximum available air pressure. For example, if the system operating pressure is 25,000 psi (1723 bar) and the available air pressure is 60 psi (4.1 bar) and an air-to-open (spring fail closed) valve is required, a 30VM or 60VM valve with a heavy duty air operator can be used.

Air-to-close

Valve Series	O.D. Tube in. (mm)	Medium		Heavy		Extra Heavy	
		System Press. psi (bar)	Air Press. psi (bar)	System Press. psi (bar)	Air Press. psi (bar)	System Press. psi (bar)	Air Press. psi (bar)
10SM	9/16 (14.3)	8,600 (593)	100 (6.9)	10,000 (690)	55 (3.8)	10,000 (690)	20 (1.4)
	3/4 (19.1)	4,800 (331)	100 (6.9)	10,000 (690)	100 (6.9)	10,000 (690)	35 (2.4)
	1 (25.4)	2,800 (193)	100 (6.9)	6,300 (434)	100 (6.9)	10,000 (690)	35 (2.4)
20SM	1/4 (6.35)	20,000 (1380)	95 (6.5)	20,000 (1380)	50 (3.5)	—	—
	3/8 (9.53)	19,000 (1310)	100 (6.9)	20,000 (1380)	55 (3.8)	—	—
	9/16 (14.3)	10,700 (734)	100 (6.9)	20,000 (1380)	85 (5.9)	20,000 (1380)	30 (2.1)
	3/4 (19.1)	6,100 (421)	100 (6.9)	13,600 (938)	100 (6.9)	20,000 (1380)	50 (3.4)
	1 (25.4)	3,900 (269)	100 (6.9)	8,800 (607)	100 (6.9)	20,000 (1380)	75 (5.1)
30SC	1 (25.4)	—	—	—	—	30,000 (2068)	80 (5.5)
30VM	1/4 (6.35)	30,000 (2068)	55 (3.8)	30,000 (2068)	30 (2.0)	—	—
	3/8 (9.53)	30,000 (2068)	75 (5.2)	30,000 (2068)	40 (2.8)	—	—
	9/16 (14.3)	30,000 (2068)	75 (5.2)	30,000 (2068)	40 (2.8)	—	—
40VM	9/16 (14.3)	—	—	40,000 (2758)	45 (3.1)	—	—
60VM	1/4 (6.35)	60,000 (4137)	75 (5.2)	60,000 (4137)	40 (2.8)	—	—
	3/8 (9.53)	60,000 (4137)	75 (5.2)	60,000 (4137)	40 (2.8)	—	—
	9/16 (14.3)	60,000 (4137)	90 (6.2)	60,000 (4137)	45 (3.1)	—	—

Air-to-open

10SM	9/16 (14.3)	7,900 (545)	95 (6.6)	10,000 (690)	75 (5.1)	10,000 (690)	40 (2.8)
	3/4 (9.1)	—	—	7,000 (483)	75 (5.1)	10,000 (690)	60 (4.1)
	1 (25.4)	—	—	4,300 (296)	75 (5.1)	10,000 (690)	85 (5.9)
20SM	1/4 (6.35)	20,000 (1380)	95 (6.6)	20,000 (1380)	50 (3.4)	—	—
	3/8 (9.53)	18,250 (1258)	95 (6.6)	18,250 (1258)	50 (3.4)	—	—
	9/16 (14.3)	9,800 (676)	95 (6.6)	15,700 (1082)	75 (5.1)	20,000 (1380)	55 (3.8)
	3/4 (19.1)	—	—	9,200 (634)	75 (5.1)	20,000 (1380)	80 (5.5)
	1 (25.4)	—	—	6,100 (420)	75 (5.1)	20,000 (1380)	100 (6.9)
30SC	1 (25.4)	—	—	—	—	30,000 (2068)	100 (6.9)
30VM	1/4 (6.35)	30,000 (2068)	75 (5.2)	30,000 (2068)	40 (2.8)	—	—
	3/8 (9.53)	30,000 (2068)	95 (6.5)	30,000 (2068)	50 (3.5)	—	—
	9/16 (14.3)	30,000 (2068)	95 (6.5)	30,000 (2068)	50 (3.5)	—	—
40VM	9/16 (14.3)	—	—	40,000 (2758)	55 (3.8)	—	—
60VM	1/4 (6.35)	60,000 (4137)	95 (6.5)	60,000 (4137)	50 (3.5)	—	—
	3/8 (9.53)	60,000 (4137)	95 (6.5)	60,000 (4137)	50 (3.5)	—	—
	9/16 (14.3)	60,000 (4137)	95 (6.5)	60,000 (4137)	50 (3.5)	—	—

Couplings



The couplings shown here permit the joining of any combination of standard size Autoclave tubing with female-to-female couplings. Other couplings available on special order.

How to use the Ordering Chart:

1. Locate "A" connection in the vertical column.
2. Locate the desired "B" connection across the top of the chart.
3. The catalog number of the required coupling is located at the intersection of the two columns.

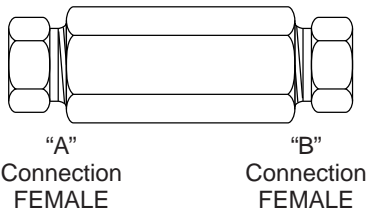

	"A" Connection			"B" Connection									
				AE Medium Pressure					AE High Pressure				
	Tube Size in.(mm)	Conn. Type	Pressure psi*(bar)	1/4 (6.35) SF250CX	3/8 (9.53) SF375CX	9/16 (14.3) SF562CX	3/4 (19.1) SF750CX	1 (25.4) SF1000CX	1 (25.4) F1000 C43	1/4 (6.35) F250C	3/8 (9.53) F375C	9/16 (14.3) F562C	9/16 (14.3) F562C40
AE Medium Pressure	1/4 (6.35)	SF250 CX	20,000 (1380)	20FX 4466	20F 4666	20F 4966	20F 41266	20F 41666	43F 41663	20F 4463	20F 4663	20F 4963	
	3/8 (9.53)	SF375 CX	20,000 (1380)		20FX 6666	20F 6966	20F 61266	20F 61666	43F 61663	20F 6463	20F 6663	20F 6963	
	9/16 (14.3)	SF562 CX	20,000 (1380)			20FX 9966	20F 91266	20F 91666		20F 9463	20F 9663	20F 9963	
	3/4 (19.1)	SF750 CX	20,000 (1380)				20FX 12	20F 121666		20F 12463	20F 12663	20F 12963	
	1 (25.4)	SF1000 CX	20,000 (1380)					20FX 16		20F 16463	20F 16663	20F 16963	
AE High Pressure	1 (25.4)	F1000 C43	43,000 (2964)						43F 16	43F 16463	43F 16663	43F 16963	
	1/4 (6.35)	F250 C	60,000 (4140)						43F 41633	60F 4433	60F 4633	60F 4933	
	3/8 (9.53)	F375 C	60,000 (4140)						43F 61633		60F 6633	60F 6933	
	9/16 (14.3)	F562C	60,000 (4140)						43F 91633			60F 9333	
	9/16 (14.3)	F562 C40	40,000 (2758)										40F 9933

Male/Female Adapters

Male/female adapters are designed to adapt a female connection direct to another size and/or type of connection. In selecting an adapter involving two different sized connections, the larger connection should be on the male end where it is possible to maximize the mechanical strength of the adapter.

To use this chart:

1. Locate MALE end in vertical column.
2. Locate desired FEMALE end of adapter across top of chart.
3. Catalog number of required adapter is located at intersection of columns.

Other Adapters

AE supplies many other types of adapters on special orders. These include AE UniVersa-Lok swaged-type connections, socketweld to O.D. tube or nominal pipe size, male or female AN connections and others.

Materials

All AE adapters are precision machined from cold-worked Type 316 stainless steel. Other materials available on special order.







Female End ▶			AE Medium Pressure					AE High Pressure				
			1/4"(6.35) SF250CX	3/8"(9.53) SF375CX	9/16"(14.3) SF562CX	3/4"(19.1) SF750CX	1"(25.4) SF1000CX	1"(25.4) F1000C43	1/4"(6.35) F250C	3/8"(9.53) F375C	9/16"(14.3) F562C	9/16"(14.3) F562C40
Male End ◀	Fits this Female Conn.	Pressure psi*(bar)	20,000 (1380)	20,000 (1380)	20,000 (1380)	20,000 (1380)	20,000 (1380)	43,000 (2964)	60,000 (4140)	60,000 (4140)	60,000 (4140)	40,000 (2758)
AE Medium Pressure	1/4 (6.35)	SF250CX	20,000 (1380)	20M46K6	20M49K6	20M412K6	20M416K6		20M44K3	20M46K3	20M49K3	
	3/8 (9.53)	SF375CX	20,000 (1380)	20M64K6	20M69K6	20M612K6	20M616K6		20M64K3	20M66K3	20M69K3	
	9/16 (14.3)	SF562CX	20,000 (1380)	20M94K6	20M96K6	20M912K6	20M916K6		20M94K3	20M96K3	20M99K3	
	3/4 (19.1)	SF750CX	20,000 (1380)	20M124K6	20M126K6	20M129K6	20M1216K6		20M124K3	20M126K3	20M129K3	20M129K40
	1 (25.4)	SF1000CX	20,000 (1380)	20M164K6	20M166K6	20M169K6	20M1612K6		20M164K3	20M166K3	20M169K3	
AE High Pressure	1 (25.4)	F1000C43	43,000 (2964)						43M164B3	43M166B3	43M169B3	43M169B40
	1/4 (6.35)	F250C	60,000 (4140)	20M44B6	20M46B6	20M49B6	20M412B6		43M416B6	60M46B3	60M49B3	
	3/8 (9.53)	F375C	60,000 (4140)	20M64B6	20M66B6	20M69B6	20M612B6	20M616B6	43M616B6	60M64B3	60M69B3	
	9/16 (14.3)	F562C	60,000 (4140)	20M94B6	20M96B6	20M99B6	20M912B6	20M916B6	43M916B6	60M94B3	60M96B3	
	9/16 (14.3)	F562C40	40,000 (2758)				20M912G6					

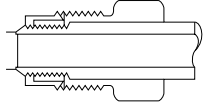
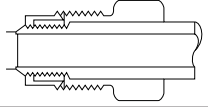
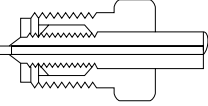







*Pressure Rating - The pressure rating of AE couplings is based on the lower rated connection used.

Fittings, Components & Accessories



	Connection Sizes in. (mm)	Pressure Rating psi (bar)	Connection Styles
Medium Pressure	1/4 to 1 (6.35 to 25.4)	to 20,000 (1380)	Coned-and-threaded type for high strength and repeated make-up. Anti-vibration collet gland available. In line collar and gland to minimize block thickness. 
High Pressure	1 (25.4)	to 43,000 (2964)	Coned-and-threaded type for high strength and repeated make-up. Anti-vibration collet gland available. 
	1/4 to 9/16 (6.35 to 14.3)	to 60,000 (4140)	Coned-and-threaded type for high strength and repeated make-up. Anti-vibration collet gland available. Nested collar and gland to minimize block width. 

								
	O.D. Tube Size in. (mm)	Pressure Rating psi (bar)	Elbow	Tee	Cross	Straight Coupling	Union Coupling	Bulkhead Coupling
Medium Pressure	1/4 (6.35)	20,000 (1380)	CLX4400	CTX4440	CXX4444	20FX4466	20UFX4466	20BFX4466
	3/8 (9.53)	20,000 (1380)	CLX6600	CTX6660	CXX6666	20FX6666	20UFX6666	20BFX6666
	9/16 (14.3)	20,000 (1380)	CLX9900	CTX9990	CXX9999	20FX9966	20UFX9966	20BFX9966
	3/4 (19.1)	20,000 (1380)	CLX12	CTX12	CXX12	20FX12	20UFX12	20BFX12
	1 (25.4)	20,000 (1380)	CLX16	CTX16	CXX16	20FX16	20UFX16	20BFX16
High Pressure	1 (25.4)	43,000 (2964)	43CL16	43CT16	43CX16	43F16	43UF16	43BF16
	9/16 (14.3)	40,000 (2760)	40CL9900	40CT9990	40CX9999	40F9933	40UF9933	40BF9933
	1/4 (6.35)	60,000 (4140)	CL4400	CT4440	CX4444	60F4433	60UF4433	60BF4433
	3/8 (9.53)	60,000 (4140)	CL6600	CT6660	CX6666	60F6633	60UF6633	60BF6633
	9/16 (14.3)	60,000 (4140)	CL9900	CT9990	CX9999	60F9933	60UF9933	60BF9933

			Connection Components			Check Valves			Line Filters		Safety Heads
	O.D. Tube Size in. (mm)	Pressure Rating psi (bar)									
			Gland	Collar	Plug	O-Ring	Ball	Excess Flow	Ball-Type Dual Disc	Cup-Type	Safety Heads
Medium Pressure	1/4 (6.35)	20,000 (1380)	CGLX40	CCLX40	CPX40	CXO4400	CXB4400	CXK4402	-	CXF4	CSX4600*
	3/8 (9.53)	20,000 (1380)	CGLX60	CCLX60	CPX60	CXO6600	CXB6602	CXK6602	-	CXF6	CSX6600*
	9/16 (14.3)	20,000 (1380)	CGLX90	CCLX90	CPX90	CXO9900	CXB9900	CXK9902	CLFX9900	CXF9	CSX9600*
	3/4 (19.1)	20,000 (1380)	CGLX120	CCLX120	CPX120	CXO12	CXB12	CXK1202	-	-	-
	1 (25.4)	20,000 (1380)	CGLX160	CCLX160	CPX160	CXO16	CXB16	CXK1602	-	CXF16	-
High Pressure	1 (25.4)	43,000 (2964)	CGLX160	CCLX160	43CP160	43CO16	43CB16	-	-	-	-
	9/16 (14.3)	40,000 (2760)	AGL90	ACL90	AP90	-	-	-	-	-	-
	1/4 (6.35)	60,000 (4140)	AGL40	ACL40	AP40	CKO4400	CB4401	CK4402	CLF4400	CF4	CS4600*
	3/8 (9.53)	60,000 (4140)	AGL60	ACL60	AP60	CKO6600	CB6601	CK6602	CLF6600	CF6	CS6600*
	9/16 (14.3)	60,000 (4140)	AGL90	ACL90	AP90	CKO9900	CB9901	CK9902	CLF9900	CF9	CS9600*

*Indicate size of rupture disc.

Tubing

Autoclave Engineers offer a complete selection of Austenetic, cold drawn stainless steel tubing designed to match the performance standards of AE valves and fittings. AE tubing is manufactured specifically for high pressure applications requiring both strength and corrosion resistance. The tubing is furnished in random lengths between 20 and 27 feet (6.1 and 8.2 meter).

Inspection and Testing

AE tubing is inspected to assure it's free of seams, laps, fissures or other flaws, as well as carburization or intergranular carbide precipitation. The outside and inside diameters of the tubing are subject to special inspection and are controlled within close tolerances to assure proper fit. Sample pieces of tube for each lot are tested to confirm mechanical properties. Hydrostatic testing is also performed on a statistical basis and is conducted at the working pressure of the tube. Autoclave will perform 100% hydrostatic testing at additional cost if desired.



Catalog Number	Tube Material	Fits Connection Type	Tube Size in.(mm)		Wall Thickness nom. in. (mm)	Flow Area in. ² (mm ²)	Working Pressures psi (bar)				
			O.D. In. (mm)	I.D. In. (mm)			-325 to 100°F (-198 to 38°C)	200°F (93°C)	400°F (204°C)	600°F (316°C)	800°F (427°C)
MS15-092	316SS	SF250CX	1/4 (6.35)	.109 (2.77)	.070 (1.78)	.009 (5.81)	20,000 (1380)	20,000 (1380)	19,250 (1330)	18,050 (1250)	16,800 (1160)
MS15-192	304SS						20,000 (1380)	18,950 (1310)	17,200 (1190)	17,000 (1170)	16,150 (1110)
MS15-093	316SS	SF375CX	3/8 (9.53)	.203 (5.16)	.086 (2.18)	.032 (20.6)	20,000 (1380)	20,000 (1380)	19,250 (1330)	18,050 (1250)	16,800 (1160)
MS15-193	304SS						20,000 (1380)	18,950 (1310)	17,200 (1190)	17,000 (1170)	16,150 (1110)
MS15-085	316SS	SF562CX	9/16 (14.3)	.312 (7.92)	.125 (3.17)	.076 (49)	20,000 (1380)	20,000 (1380)	19,250 (1330)	18,050 (1250)	16,800 (1160)
MS15-187	304SS						20,000 (1380)	18,950 (1310)	17,200 (1190)	17,000 (1170)	16,150 (1110)
MS15-097	316SS	SF562CX	9/16 (14.3)	.359 (9.12)	.101 (2.56)	.101 (65.2)	10,000 (690)	10,000 (690)	9,600 (662)	9,100 (627)	8,450 (583)
MS15-194	304SS						10,000 (690)	9,450 (652)	8,600 (593)	8,500 (586)	8,050 (555)
MS15-095	316SS	SF750CX	3/4 (19.1)	.438 (11.1)	.156 (3.96)	.151 (97.4)	20,000 (1380)	20,000 (1380)	19,250 (1330)	18,050 (1250)	16,800 (1160)
MS15-098	316SS						10,000 (690)	10,000 (690)	9,600 (662)	9,100 (627)	8,450 (583)
MS15-096	316SS	SF1000CX	1 (25.4)	.562 (14.3)	.219 (5.56)	.248 (160)	20,000 (1380)	20,000 (1380)	19,250 (1330)	18,050 (1250)	16,800 (1160)
MS15-099	316SS						10,000 (690)	10,000 (690)	9,600 (662)	9,100 (627)	8,450 (583)
MS15-199	304SS	F1000C43	1 (25.4)	.438 (11.1)	.281 (7.14)	.151 (97.4)	43,000 (2964)	40,635 (2802)	36,950 (2548)	36,290 (2502)	34,720 (2394)
MS15-189	304SS	F562C40	9/16 (14.3)	.25 (6.35)	.156 (4.02)	.048 (31)	40,000 (2760)	36,800 (2537)	31,650 (2182)	30,700 (2392)	28,450 (1962)
MS15-081	316SS	F250C	1/4 (6.35)	.083 (2.11)	.083 (2.11)	.005 (3.22)	60,000 (4140)	60,000 (1380)	57,750 (1380)	54,250 (1380)	50,700 (1380)
MS15-182	304SS						60,000 (4140)	56,800 (3910)	51,650 (3560)	50,700 (3500)	48,450 (3340)
MS15-087	316SS	F375C	3/8 (9.53)	.125 (3.18)	.125 (3.18)	.012 (7.74)	60,000 (4140)	60,000 (4140)	57,750 (3980)	54,250 (3740)	50,700 (3490)
MS15-183	304SS						60,000 (4140)	56,800 (3910)	51,650 (3560)	50,700 (3500)	48,450 (3340)
MS15-083	316SS	F562C	9/16 (14.3)	.187 (4.78)	.187 (4.78)	.028 (18)	60,000 (4140)	60,000 (4140)	57,750 (3980)	54,250 (3740)	50,700 (3490)
MS15-185	304SS						60,000 (4140)	56,800 (3910)	51,650 (3560)	50,700 (3500)	48,450 (3340)

Note: For autofrettage tubing, add suffix "ESR42" to the tubing part number.

Coned-and-threaded Nipples



For rapid system make-up, AE supplies pre-cut, coned-and-threaded nipples in various sizes and lengths for AE valves and fittings.

Special lengths

In addition to the standard lengths listed in the table below, nipples are available in any custom length. Consult factory.

Materials

Catalog numbers in table refer to Type 316 stainless steel, unless specified.



Working Fits Connection Type	Tube Size in.(mm)		Pressure at 100°F(38°C) psi(bar)	Catalog Number						
	O.D.	I.D.		2.75" Length	3" Length	4" Length	6" Length	8" Length	10" Length	12" Length
SF250CX	1/4 (6.35)	.109 (2.77)	20,000 (1380)	CNX4402		CNX4404	CNX4406	CNX4408	CNX44010	CNX44012
SF375CX	3/8 (9.53)	.203 (5.16)	20,000 (1380)		CNX6603	CNX6604	CNX6606	CNX6608	CNX66010	CNX66012
SF562CX	9/16 (14.3)	.312 (7.92)	20,000 (1380)			CNX9904	CNX9906	CNX9908	CNX99010	CNX99012
SF562CX	9/16 (14.3)	.359 (9.12)	10,000 (690)			CNLX9904	CNLX9906	CNLX9908	CNLX99010	CNLX99012
SF750CX	3/4 (19.1)	.438 (11.1)	20,000 (1380)				CNX1206	CNX1208	CNX12010	CNX12012
SF750CX	3/4 (19.1)	.515 (13.1)	10,000 (690)				CNLX1206	CNLX1208	CNLX12010	CNLX12012
SF1000CX	1 (25.4)	.562 (14.3)	20,000 (1380)				CNX1606	CNX1608	CNX16010	CNX16012
SF1000CX	1 (25.4)	.688 (17.5)	10,000 (690)				CNLX1606	CNLX1608	CNLX16010	CNLX16012
F1000C43	1 (25.4)	.438 (11.1)	43,000 (2964)				43CN1606-304	43CN1608-304	43CN16010-304	43CN16012-304
F562C40	9/16 (14.3)	.250 (6.35)	40,000 (2760)			40CN9904-304	40CN9906-304	40CN9908-304	40CN99010-304	40CN99012-304
F250C	1/4 (6.35)	.083 (2.11)	60,000 (4140)	CN4402	CN4403	CN4404	CN4406	CN4408	CN44010	CN44012
F375C	3/8 (9.53)	.125 (3.18)	60,000 (4140)		CN6603	CN6604	CN6606	CN6608	CN66010	CN66012
F562C	9/16 (14.3)	.187 (4.78)	60,000 (4140)			CN9904	CN9906	CN9908	CN99010	CN99012

Anti Vibration Collet Gland Assemblies

Vibration and/or shock can be present in tubing systems, especially if the valve or fitting happens to be located on an unsupported line near a compressor. For this reason, Autoclave Engineers coned-and-threaded connections are offered with the AE Anti-Vibration Collet Gland Assemblies. Completely interchangeable with standard AE high pressure connections, the Collet Gland Assemblies provide equally effective pressure handling capability.

O.D. Tubing Size in. (mm)	Catalog Number	
	Medium Pressure to 20,000	High Pressure to 60,000
1/4 (6.35)	KCBGLX40-316MC	KCGL40-316
3/8 (9.53)	KCBGLX60-316MC	KCGL60-316
9/16 (14.3)	KCBGLX90-316MC	KCGL90-316
3/4 (19.1)	KCBGLX120-316MC	-
1 (25.4)	KCBGLX160-316MC	†KCBGLX160-316MC

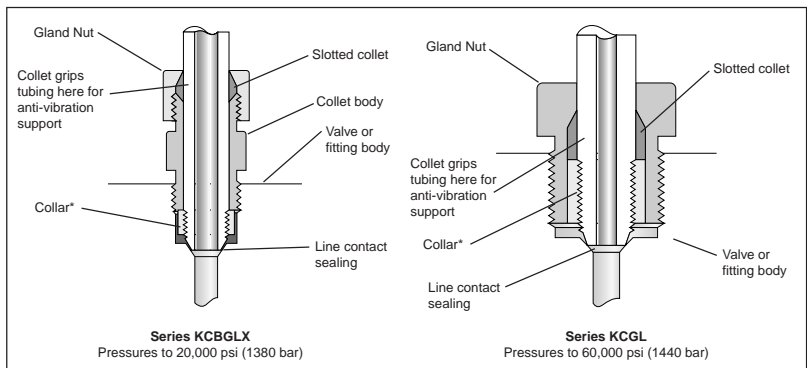

† 1" High Pressure to 43,000 psi (2964 bar)

*AE Collar not included in complete assembly.

AE Instrument Quality Gauges



Materials and features

- Accuracy within $\pm 0.5\%$ of full scale range
- Plastic dial cover/solid front aluminum alloy case
- Blow-out back panel for pressure relief in the event of Bourdon tube failure
- 316 Stainless steel Bourdon tubes**
- Precision stainless steel movement for accuracy and resistance to atmospheric corrosion
- Pointer zero adjustment located on front of gauge behind dial cover for convenience

Instrument quality gauges

- Flush panel mounting - Interchangeable dial cover retaining rings are stocked to permit flush panel mounting of any instrument quality gauge. These will be furnished at an additional charge when specified on order -- add "PM" to order number.
- Optional electrical contact face - Available for all instrument quality gauges. With adjustable low and high electrical contacts, this option permits gauges to provide pressure control for automatic or remote operation, or for fail-safe set points.

** Bourdon Tube material for 0-80,000 psi (0-5116 bar) and 0-50,000 psi (0-3447 bar) gauge is Inconel 718.
Bourdon Tube material for 0-30,000 psi (0-2068 bar) gauge is K Monel.

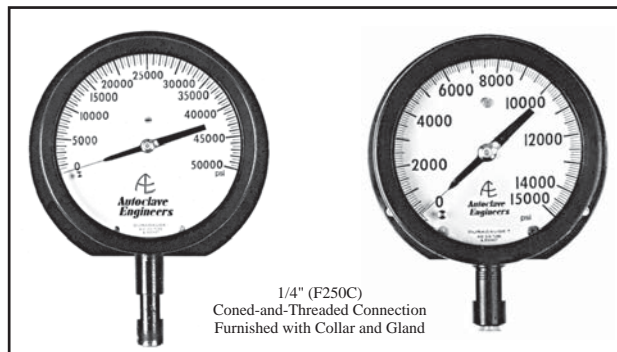

Calibrated in psi Only			
Catalog Number	Pressure Range (psi)	Minor Interval Value (psi)	Dial Diameter (inches)
P-0499-CG	0-1000	10	4-1/2
P-0479-CG	0-1500	10	4-1/2
P-0480-CG	0-3000	20	4-1/2
P-0481-CG	0-5000	50	4-1/2
P-0482-CG	0-10,000	100	4-1/2
P-0483-CG	0-15,000	100	4-1/2
P-0487-CG	0-20,000	200	4-1/2
P-0488-CG**	0-30,000	200	6
P-0489-CG**	0-50,000	500	6
P-0490-CG**	0-80,000	1,000	6

Optional Electrical Contact Face	
Catalog Number	Fits Gauge Dial Diameter (inches)
P-0713	4-1/2
P-0714	6

Specialty Products



Ball Valves

AE ball valves are designed for on-off, high flow applications. With the valve fully open the straight-through design minimizes pressure drop.

AE ball valves are economical and easy to maintain for long service life. One piece, trunnion mounted style stem design eliminates shear failure and reduces the effects of side loading found in two piece designs. Seat glands may be retightened for extended use. Operating torque is low to reduce wear and extend the life of parts.

The AE ball valve is designed to operate safely at pressures up to 20,000 psi @ 200°F (1380 bar @ 93° C) and temperatures up to 500°F @ 5,000 psi (260° C @ 345 bar). AE Ball Valves are available in 2 and 3 way designs with orifice sizes of .187" to .500" (4.7 mm to 12.7 mm). Features include 316SS construction, PEEK seats, one piece trunion stems and low friction stem seals.

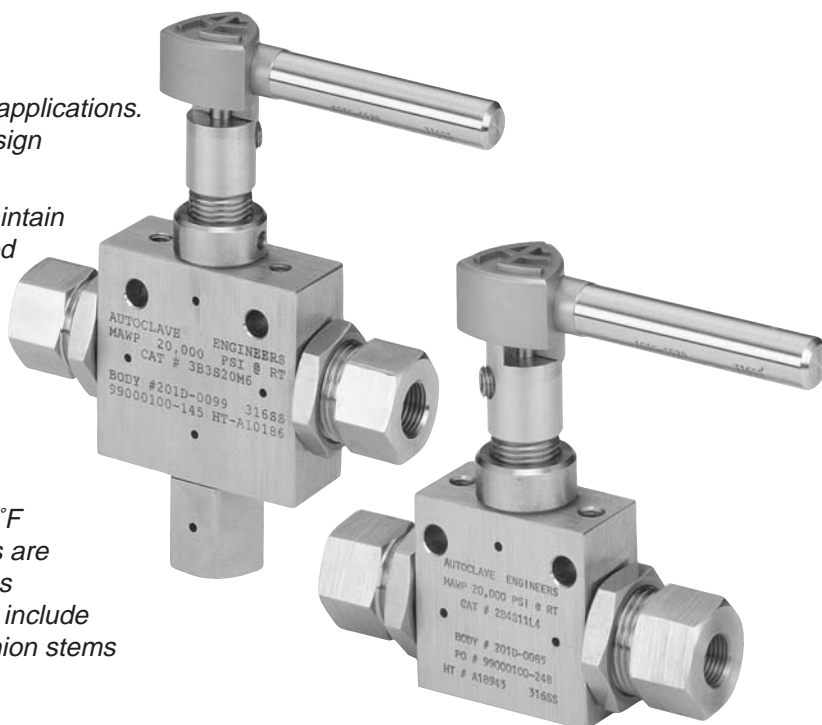

Series RVP & RVS

Series RVP & RVS relief valves provide reliable venting of gases or liquids for set pressures from 1,500 psi (103 bar) to 60,000 psi (4140 bar). Standard temperature range on RVP models is -423°F to 400°F (-253° C to 204° C). High temperature option to 750°F (400° C) also available. Temperature range on RVS model is 32°F to 400°F (0°C to 204°C). (Note: Seat material is Arlon).

These precision valves are designed for pressure gas systems, cryogenic systems, petrochemical applications and other special systems. They are capable of handling air, gases, steam, vapor and liquids. They are not recommended for steam boiler applications and are not ASME code stampable.

Relief valves are designed to open proportionally to increasing back pressure and, therefore, are not recommended for applications requiring immediate full valve flow at set pressure (such as decompositions, polymerizations, etc.). Full flow of relief valve is defined at 10% over set pressure.

Catalog Number	Connection Size & Type (inches)		Orifice in. (mm)	Pressure Rating PSIG @ 100°F (bar @ 38°C)		
	Inlet	Outlet FNPT		Min Set	Max Set	Max Back
5RVP9072	SF562CX	3/4 (19.1)	.312 (7.92)	1,500 (103)	5,000 (345)	500 (34.5)
10RVP9072	SF562CX	3/4 (19.1)	.250 (6.35)	5,000 (345)	10,000 (690)	500 (34.5)
15RVP9072	SF562CX	3/4 (19.1)	.188 (4.78)	10,000 (689)	15,000 (1034)	500 (34.5)
20RVP9072	SF562CX	3/4 (19.1)	.156 (4.02)	15,000 (1034)	20,000 (1379)	500 (34.5)
30RVP6072	F375C	3/4 (19.1)	.125 (3.18)	20,000 (1379)	30,000 (2068)	500 (34.5)
45RVP9072	F562C	3/4 (19.1)	.093 (2.36)	25,000 (1724)	45,000 (3103)	500 (34.5)
60RVP6072	F375C	3/4 (19.1)	.078 (1.98)	30,000 (2060)	60,000 (4137)	500 (34.5)
Soft Seat						
10RVS9072	SF562CX	3/4 (19.1)	.250 (6.35)	5,000 (345)	10,000 (690)	500 (34.5)
20RVS9072	SF562CX	3/4 (19.1)	.156 (4.02)	10,000 (690)	20,000 (1379)	500 (34.5)



Manifold Block

Specialty pressure manifolds minimize space requirements and reduce installation time necessary to plumb a pressure system. In addition, by reducing the number of components used in a system, manifolds reduce the number of potential leak joints.

Autoclave Engineers will design and build pressure manifolds to meet specific installation, layout and pressure requirements. These manifolds are capable of withstanding pressures from vacuum to 60,000 psi (4137 bar), and are available in a variety of materials and sizes. Among the pressure connections that can be incorporated are Autoclave low, medium and high pressure, NPT, SAE, BSP and others. Transitions in system line sizes and tubing pressure series can be accomplished through a specialty manifold. These manifolds are appropriate wherever pressure tubing systems are utilized.





AE Micrometer Adjustable Torque Wrench (P-1680)

Accurate tightening for all AE valve packing glands and tube nuts is essential. The wrench can be adjusted from 20 to 150 ft.-lbs. (27 to 203 N/M) and is used with interchangeable wrench adapters for hex sizes from 1/2" through 1-1/2". Part numbers for wrench adapters are listed on chart.

Packing Gland or Tube Nut Hex Size in. (mm)	1/2 (12.7)	9/16 (14.3)	5/8 (15.9)	11/16 (17.5)	3/4 (19.05)	13/16 (20.6)	7/8 (22.2)	15/16 (23.8)	1 (25.4)	1-1/16 (27)	1-3/16 (30.2)	1-3/8 (34.9)	1-1/2 (38.1)
Wrench Adapter Number	P-1681	P-1682	P-1683	P-1684	P-9813	P-1685	P-1686	P-1687	P-9901	P-1688	P-1689	P-1690	P-6040

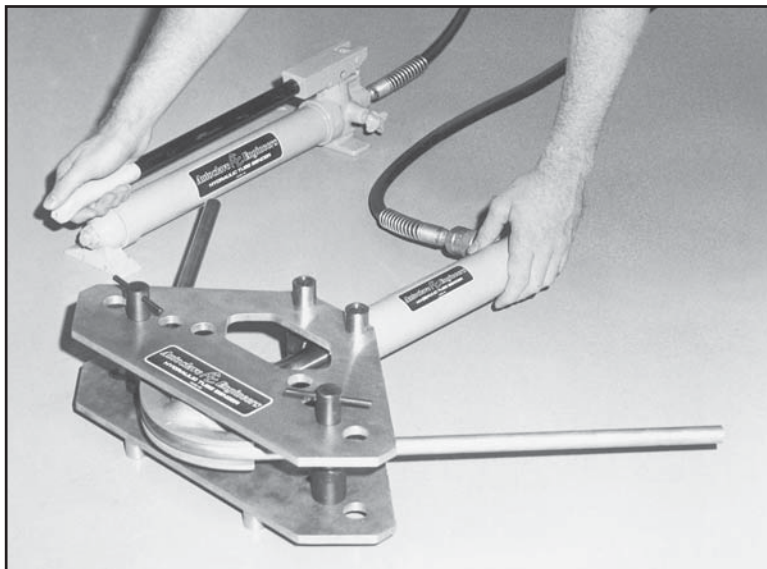
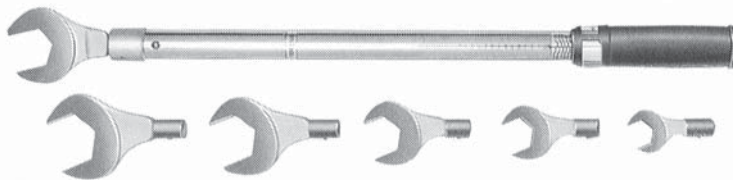

Hydraulic Tube Bender

For single pass bending of high pressure tubing. The AE hydraulic tube bender is designed to bend heavy wall tubing quickly, accurately and reliably with only one setup. The tube bender is complete with pump, cylinder, frame and bending shoes which are self-contained in a portable, lockable case. (Order number: HTB)

Air operated hydraulic pump option available in place of hand pump. (Order Number: HTB-A)

Coning and Threading Machine

Ordering Procedure: Model # AEGCTM-2

Separate heads for coning and threading are powered by a single motor and drive system. Model AEGCTM-2 cones and threads AE medium and high pressure tubing.

Approximate dimensions: 56" high, 28" wide and 20" deep (1.4 m x .7 m x .5 m).

Shipping weight is 350 pounds (159 kg). Tooling must be ordered separately. Consult factory.

Features

- ◆ One-half hp motor, 115/230 VAC 60 Hz (220 VAC 50 Hz) volt capacitor start.
- ◆ No reversing necessary on threading operation; pop-open die prevents thread damage.
- ◆ Complete tooling is available; specify tooling sizes required.
- ◆ Coning head has feed wheel for easy, precision feeding.
- ◆ Complete with oil pump and reservoir.
- ◆ Unit mounted on stand complete with locking casters for ease of mobility and stability.
- ◆ Available CE mark and with optional reservoir heater



Manual Coning & Threading Tools

Autoclave Engineers manufactures a manual coning tool for optimum coning performance with tubing sizes up to 9/16" (14.3 mm) O.D. This is a precision quality manual tool to permit on-site end preparation for AE medium and high pressure tubing installations. Interchangeable collets for each size tubing provide proper centering of tubing. The cutting feed arrangement permits the operator to control the depth of cut to assure against work hardening effects. Interchangeable tool steel cutting blades are used in pairs to assure more accurate and faster coning and are designed to square-off and finish the tube as the cone is completed. There is a provision for applying metal cutting lubricants to the cutting zone.

The threading die holder is designed to hold the appropriate die for any of the standard AE tubing sizes through 9/16" (14.3 mm) O.D. Interchangeable guide bushings properly guide the tool for accurate thread cutting.

Note: Complete tool kits are available. Consult factory

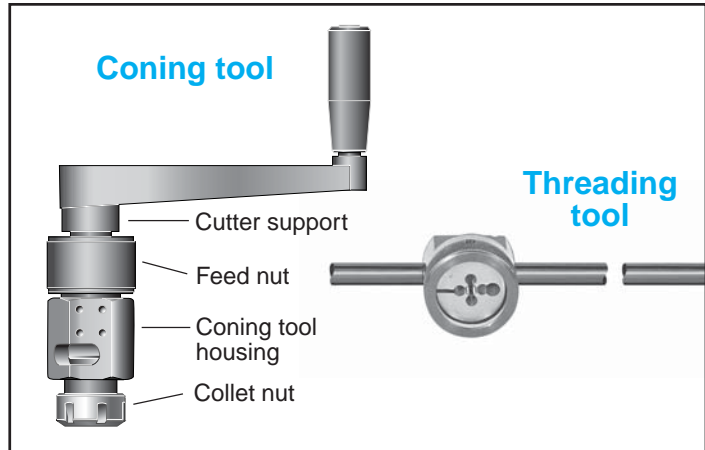

	Tube Size		Coning Tools and Components Catalog Number			Threading Tools and Components Catalog Number				
	O.D. in.(mm)	I.D. in.(mm)	Tool with Collet & Blades	Collet	Coning Blades (set of 2)	Tool with Die & Bushing	Tool Only	Threading Die		Guide Bushing
								Order No.	Size-type*	
AE Medium Pressure	1/4 (6.35)	.109 (2.77)	MCTM4	90248	101F-1577	402A	402	P-0214	1/4-28	1010-0343
	3/8 (9.53)	.203 (5.16)	MCTM6	90250	101F-1601	402C	402	P-0215	3/8-24	1010-0344
	9/16 (14.3)	.312 (7.92)	MCTM920	90251	1010-5218	402E	402	P-0216	9/16-18	1010-0345
	9/16 (14.3)	.359 (9.12)	MCTM910	90251	101A-1897	402E	402	P-0216	9/16-18	1010-0345
AE High Pressure	1/4 (6.35)	.083 (2.11)	MCTH4	90248	101F-1577	402A	402	P-0214	1/4-28	1010-0343
	3/8 (9.53)	.125 (3.18)	MCTH6	90250	101F-1578	402C	402	P-0215	3/8-24	1010-0344
	9/16 (14.3)	.188 (4.78)	MCTH960	90251	1010-0883	402E	402	P-0216	9/16-18	1010-0345
	9/16 (14.3)	.250 (6.35)	MCTH940	90251	101C-7214	402E	402	P-0216	9/16-18	1010-0345

Cutting Oil: P-8784

*All threads for AE medium pressure and high pressure tubing are LH national fine (class 2).

Note: Manual coning and threading tools for 3/4" (19.1 mm) and 1" (25.4 mm) O.D. medium pressure tubing are not available. Model AEGCTM-2 Power Coning-and-Threading Machine is recommended for this tubing. A minimum of 3" (76 mm) straight length is required to perform coning and threading operation for manual coning tool.

Flow Calculations



Coefficient of flow (C_v) for a valve is the volume of water in U.S. gallons per minute at room temperature...which will flow through the valve with the stem fully open...with a pressure drop of 1 psi across the valve. C_v is the valve sizing factor that permits selection of the appropriate valve to meet the flow requirements of a given fluid system.

The C_v values shown on the valve ordering pages represent the full-open C_v for that valve. In determining estimated capacity, this C_v value should be used in the formulas which follow.

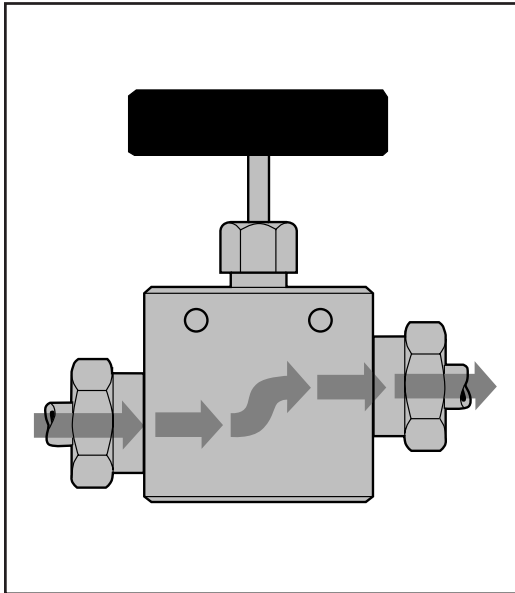

Flow Formulas

Liquids

- Flow, U.S. gal./min.
- Flow, lb./hr.

$$V = \frac{C_v \sqrt{P_1 - P_2}}{\sqrt{S_{GF}}}$$

$$W = 500 C_v \sqrt{(P_1 - P_2) / S_{GF}}$$

Gases

- Flow, SCFH
- Flow, SCFH (temperature corrected)
- Flow, lb./hr.

$$Q = \frac{42.2 C_v \sqrt{(P_1 - P_2) (P_1 + P_2)}}{\sqrt{S_{GF}}} \dagger$$

$$Q = \frac{963 C_v \sqrt{(P_1 - P_2) (P_1 + P_2)}}{\sqrt{S_{GF} T_F}} \dagger$$

$$W = 3.22 C_v \sqrt{(P_1 - P_2) (P_1 + P_2) / S_G} \dagger$$

Saturated Steam

- Flow, lb./hr.

$$W = 2.1 C_v \sqrt{(P_1 - P_2) (P_1 + P_2)} \dagger$$

Super Heated Steam

- Flow, lb./hr.

$$W = \frac{2.1 C_v \sqrt{(P_1 - P_2) (P_1 + P_2)}}{(1 + 0.0007 T_s)} \dagger$$

Specific gravity (S_G) typical gases

Gas	S_G @ RT Relative to Air
Acetylene	0.897
Air	1.000
Ammonia	0.587
Argon	1.377
Butane	2.070
Carbon dioxide	1.516
Ethylene	0.967
Helium	0.138
Hydrogen	0.0695
Methane	0.553
Nitrogen	0.966
Oxygen	1.103
Propane	1.562
Sulphur dioxide	2.208

Specific gravity (S_{GF}) typical gases

Gas	S_{GF} @ RT Referred to Water
Acetone	0.792
Alcohol	0.792
Benzine	0.902
Gasoline	0.751
Gasoline, nat.	0.680
Kerosene	0.815
Pentane	0.624
Water	1.000

Formula Nomenclature

- V = Flow, U.S. gallons per minute (GPM)
- Q = Flow, standard cu. ft. per hr. (SCFH)
- W = Flow, pounds per hour (lb./hr.)
- P_1 = Inlet pressure, psia (14.7 + psig)
- P_2 = Outlet pressure, psia (14.7 + psig)
- S_{GF} = Liquid specific gravity (water = 1.0)
- S_G = Gas specific gravity (air = 1.0)
- T_F = Flowing temp., °R absolute (460 + °F)
- T_s = Superheat in °F
- C_v = Valve coefficient of flow, full open

*Effect of flowing temperatures on gas flow are minimal for temperatures between 30°F and 150°F. Correction should be included if temperatures are higher or lower.

† Where outlet pressure P_2 is less than $1/2$ inlet pressure P_1 , the term:
 $\sqrt{(P_1 - P_2) (P_1 + P_2)}$: becomes $0.87 P_1$.

Note: Maximum C_v values in this catalog have been determined in accordance with the Fluid Controls Institute report FCI 58-2. "Recommended Voluntary Standards for Measurement Procedure for Determining Control Valve Flow Capacity," including procedure, design of the test stand and evaluation of the data.



AE Medium Pressure SFCX

Tube O.D. in. (mm)	Connection Type	Dimensions inches (mm)					
		A	B	C	D	F	H
1/4 (6.35)	SF250CX20	25/64	7/16 -20	.28 (7.11)	.50 (12.7)	.19 (4.83)	.109 (2.77)
3/8 (9.53)	SF375CX20	33/64	9/16 -18	.38 (9.65)	.62 (15.7)	.31 (7.87)	.203 (5.16)
9/16 (14.3)	SF562CX20	3/4	13/16 -16	.44 (11.2)	.75 (19.1)	.50 (12.7)	.359 (9.12)
3/4 (19.1)	SF750CX20	61/64	3/4 -14 _z	.50 (12.7)	.94 (23.9)	.62 (15.7)	.516 (13.1)
1 (25.4)	SF1000CX20	1-19/64	1-3/8 -12	.81 (20.6)	1.31 (33.3)	.88 (22.4)	.688 (17.5)

AE High Pressure FC

Tube O.D. in. (mm)	Connection Type	Dimensions inches (mm)					
		A	B	C	D	F	H
1/4 (6.35)	F250C	33/64	9/16 -18	.38 (9.65)	.44 (11.2)	.17 (4.32)	.094 (2.39)
3/8 (9.53)	F375C	11/16	3/4 -16	.53 (13.5)	.62 (15.7)	.26 (6.60)	.125 (3.18)
9/16 (14.3)	F562C	1-3/64	1-1/8 -12	.62 (15.7)	.75 (19.1)	.38 (9.65)	.188 (4.78)
9/16 (14.3)	F562C40	1-3/64	1-1/8 -12	.62 (15.7)	.75 (19.1)	.38 (9.65)	.250 (6.35)
1 (25.4)	F1000C43	1-19/64	1-3/8 -12	.81 (20.6)	1.31 (33.3)	.88 (22.4)	.438 (11.1)

Note: All dimensions are shown for reference only and should not be considered as actual machining dimensions.

*For port Diameter please see orifice sizes for specific valves and fittings.

All threads are manufactured to a class 2A or 2B fit.

! WARNING !

FAILURE OR IMPROPER SELECTION OR IMPROPER USE OF THE PRODUCTS AND/OR SYSTEMS DESCRIBED HEREIN OR RELATED ITEMS CAN CAUSE DEATH, PERSONAL INJURY AND/OR PROPERTY DAMAGE.

This document and other information from Snap-tite, Inc., its subsidiaries and authorized distributors, provides product and/or system options for further investigation by users having technical expertise. It is important that you analyze all aspects of your application and review the information concerning the product or system in the current product catalog. Due to the variety of operation conditions and applications for these products or systems, the user, through its own analysis and testing, is solely responsible for making the final selection of the products and systems and assuring that all performance, safety and warning requirements of the application are met.

The products described herein, including without limitation, product features, specifications, designs, availability and pricing, are subject to change by Snap-tite, Inc. and its subsidiaries at any time without notice.



Industrial Estate
Whitemill - Wexford
Republic of Ireland
PH: 353-53-41566 FAX: 353-53-41582
e-mail: ste_sales@snap-tite.com
www.snap-tite.com



Fluid Components
Division of Snap-tite, Inc.
8325 Hessinger Drive
Erie, Pennsylvania 16509 USA
PH: 814-838-5700 FAX: 814-838-5811
e-mail: ae_sales@snap-tite.com
www.autoclaveengineers.com

**ISO-9001
Certified**